

TECHNOLOGY FOR EXCELLENCE

UMOB

IMPIANTO OLEODINAMICO
PER REALIZZARE SCATOLE

-ROBUSTO
-VELOCE
-EFFICIENTE

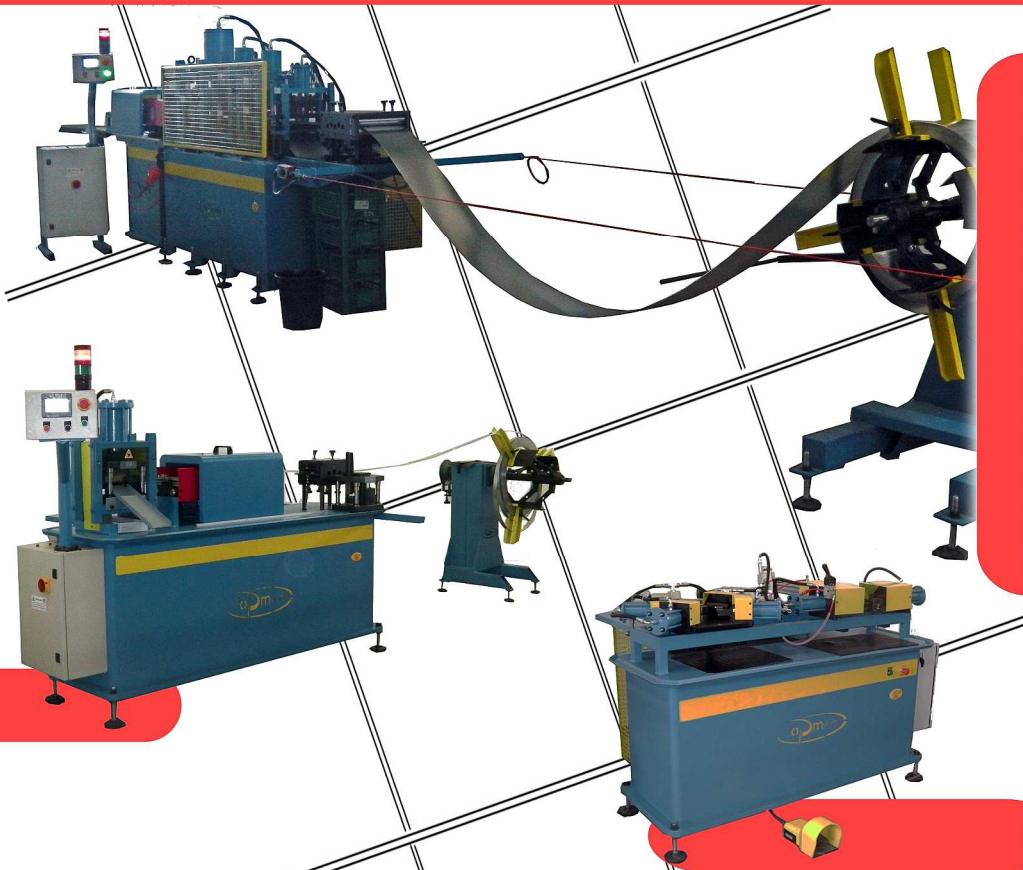

OPMSTAMPI.COM



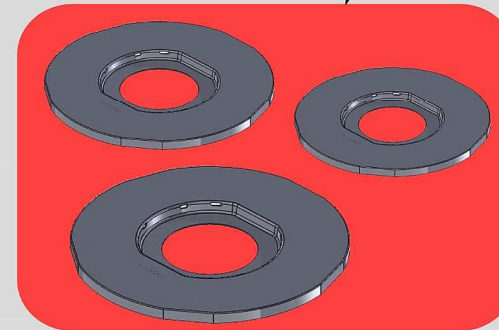
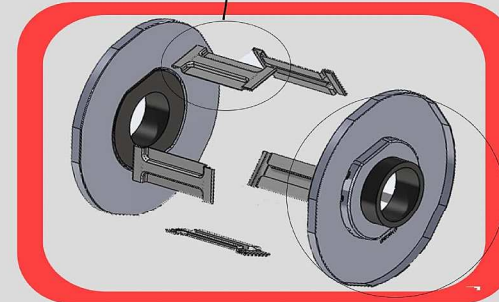
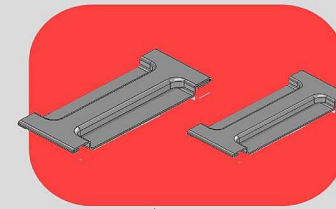

SYSTEM INTEGRATED
OF PUNCHING

UMOB
IMPIANTO OLEODINAMICO
PER REALIZZARE SCATOLE



oPm stampi srl
ss.dei due principati,83
84081 Baronissi Salerno Italy
info +39 089955527
+39 089878699
info@opmstampi.com
www.opmstampi.com

 Linea dedicata al settore Serranda in grado di soddisfare, sia per la versatilità che per la velocità di produzione, le molteplici esigenze dei produttori di Serrande.
L'impianto realizza / assembla partendo da materia prima i componenti necessari per costruire le scatole portamolle per serrande.

 Line dedicated to the sector damper able to meet, for both the versatility for the production speed, the multiple needs of manufacturers of dampers.
The plant manufactures / assembles from the material components required to build the spring boxes for rolling shutters.

 Ligne dédiée à l'amortisseur en mesure de répondre, à la fois pour la polyvalence de la vitesse de production du secteur, les multiples besoins des fabricants d'amortisseurs.
L'usine fabrique / assemble des composants matériels nécessaires à la construction des boîtes à ressorts pour volets roulants.

 Línea dedicada a la compuerta del sector capaz de cumplir, por tanto la versatilidad de la velocidad de producción, las múltiples necesidades de los fabricantes de amortiguadores.
La planta fabrica / ensambla de los componentes materiales necesarios para construir las cajas de resorte para las cortinas de enrollar.

CHIEDERE LE CARATTERISTICHE TECNICHE
AL NS UFFICIO TECNICO

FOR THE SPECIFIC TECHNIQUES CHARACTERISTICS
PLEASE CONTACT OUR OFFICE